

Mid-Year Review #2 SAR

Base your answers to questions 1 through 3 on on the diagram below, which shows laboratory materials used for an investigation of the effects of sediment size on permeability, porosity, and water retention. Four separate columns, labeled A through D, were filled to the same level with different sediments. The sediments within each column are of uniform size.

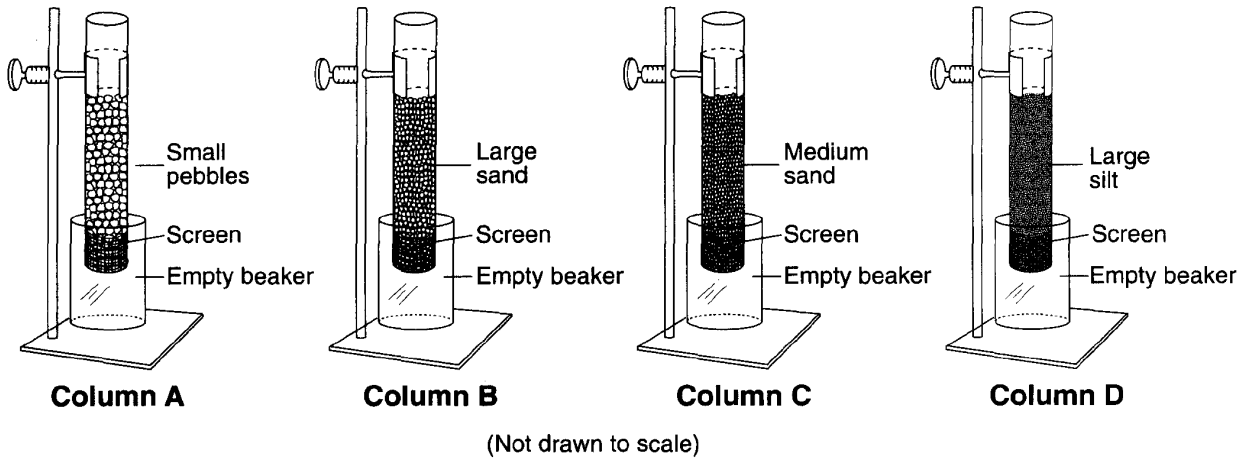

1. Describe the relationship between the sediment size and the permeability that will be observed when water is poured through these sediments.

2. An equal amount of water is poured through each column. On the grid, draw a line to show the relative amount of water retained in the sediment after the water flows through each column.

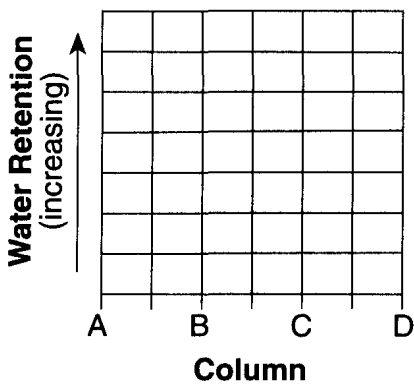

3. Which column contains particles with a diameter of 0.4 cm?

4. Base your answer to the following question on the map and the stream data table below. The map represents a stream flowing into a lake. An arrow shows the direction of streamflow. Points *A* and *B* are locations at the edge of the stream. Line *AB* is a reference line across the stream surface. Line *CD* is a reference line along the lake bottom from the mouth of the stream into the lake. The data table gives the depth of the water and distance from point *A*, in feet, along line *AB*.

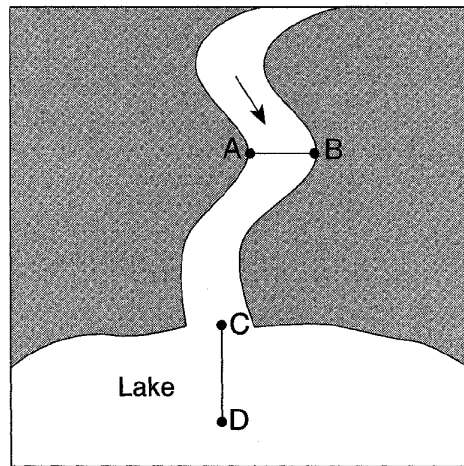

	Point A	Stream Data Table									Point B
Distance from Point A (ft)	0	10	20	30	40	50	60	70	80	90	
Depth of Water (ft)	0	2	4	7	11	13	16	17	10	0	

Using the map and the data table, explain why the depth of water 20 feet from point *A* is different from the depth of water 20 feet from point *B*.

5. Base your answer to the following question on the block diagrams below, which show three types of streams with equal volumes.

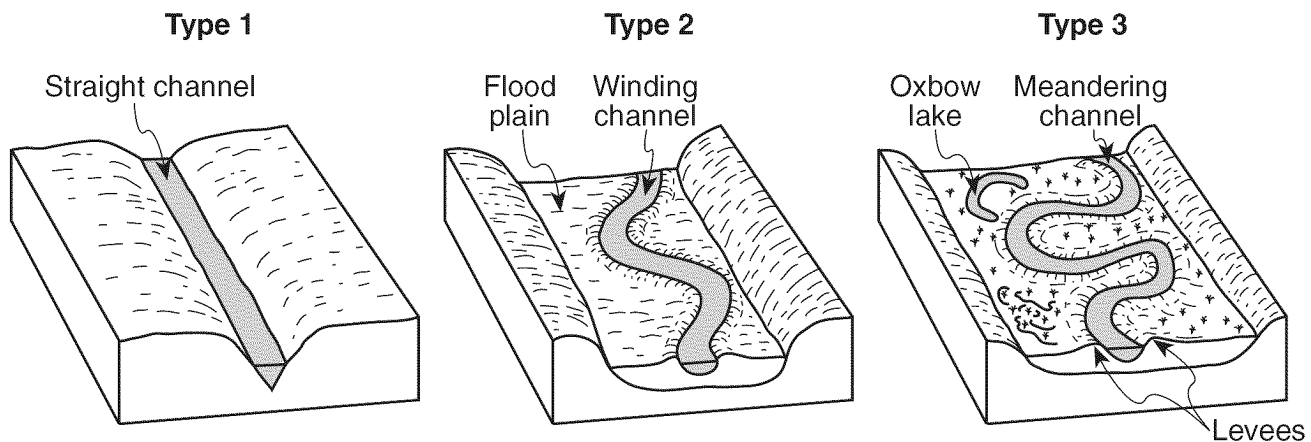

Explain why the outside of the curve of a meandering channel experiences more erosion than the inside of the curve.

6. Base your answer to the following question on the map below, which shows the different lobes (sections) of the Laurentide Ice Sheet, the last continental ice sheet that covered most of New York State. The arrows show the direction that the ice lobes flowed. The terminal moraine shows the maximum advance of this ice sheet.

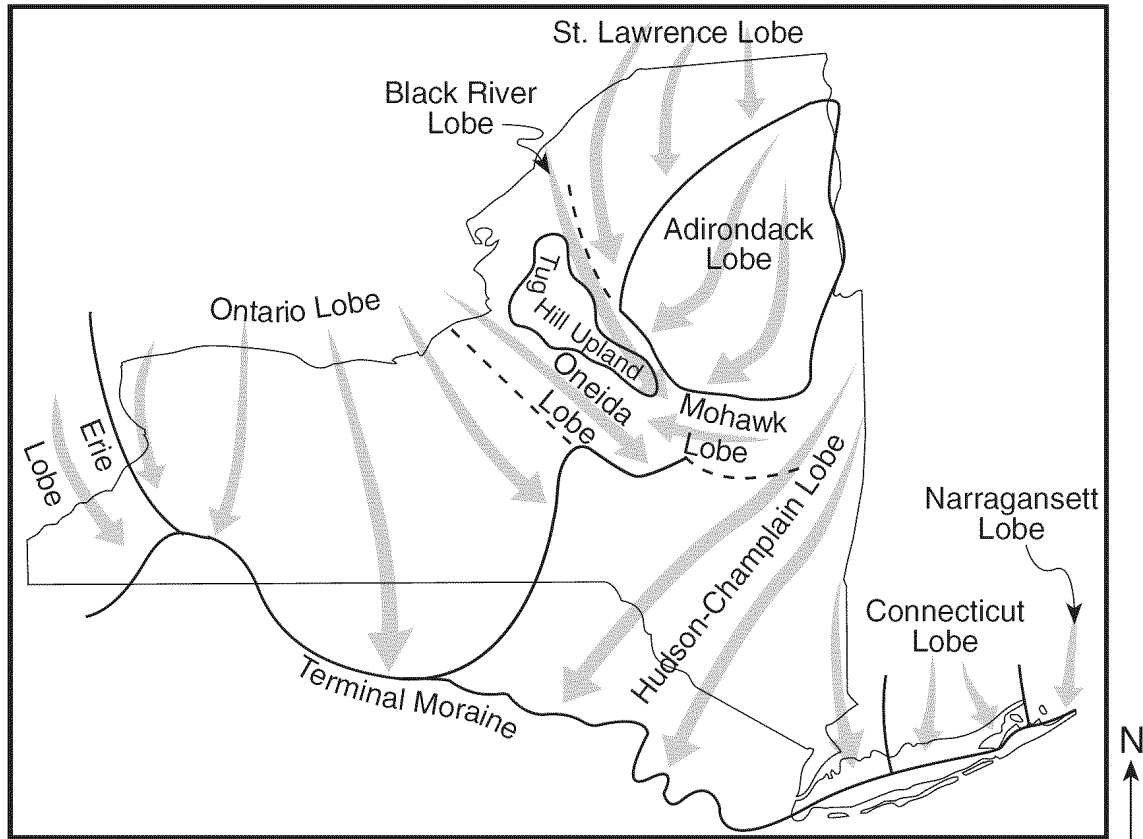

Describe the arrangement of rock material in the sediments that were directly deposited by the glacier.

7. Base your answer to the following question on the topographic map below, which shows a small island in an ocean. Points *A*, *B*, *C*, and *D* represent surface locations on the island. The symbol $\triangle 134$ represents an elevation on the hilltop. Elevations are measured in feet and distances are measured in miles.

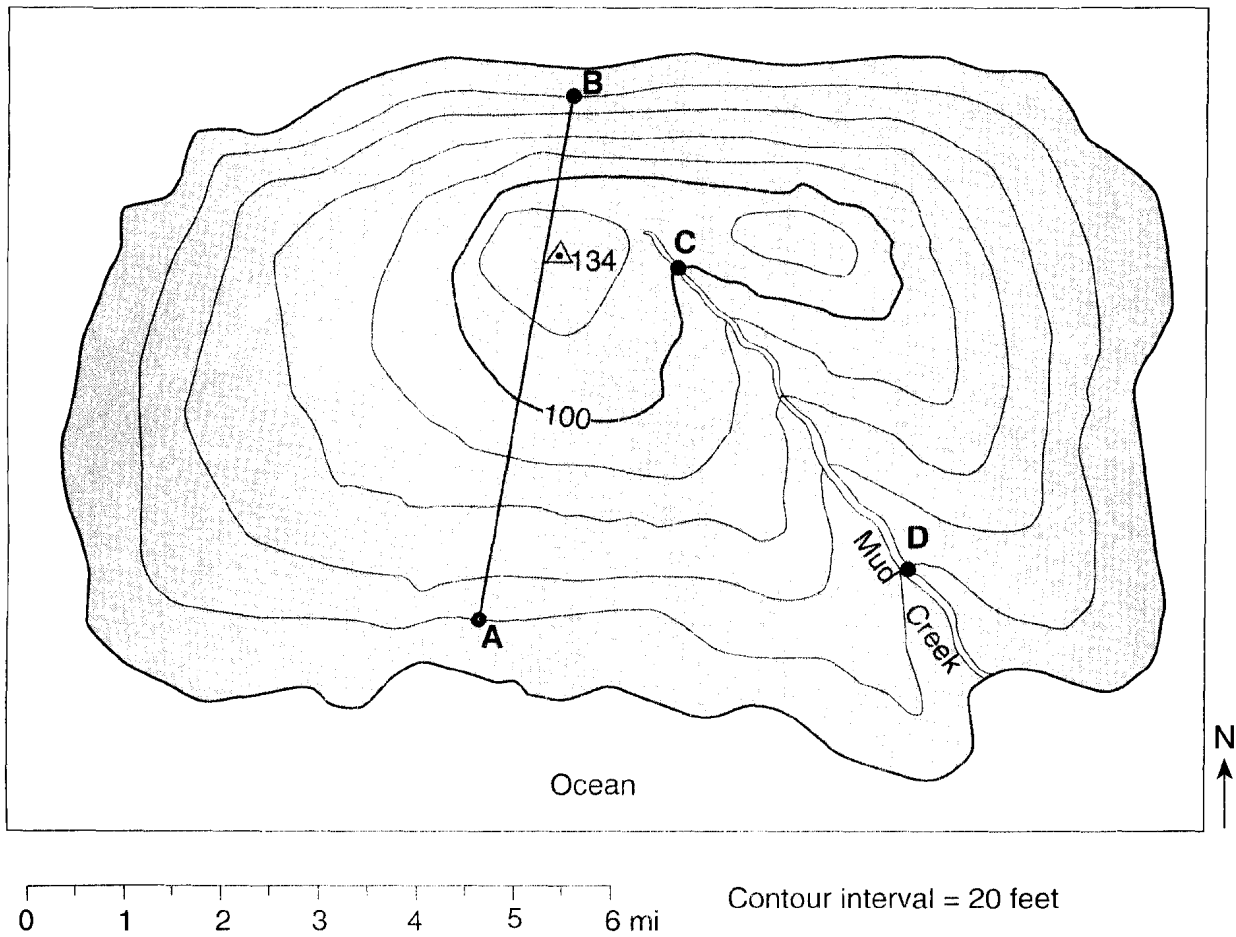

On the grid below, construct a profile along line *AB* by plotting an **X** for the elevation of *each* contour line that crosses line *AB*. Connect the **Xs** with a smooth, curved line to complete the profile.

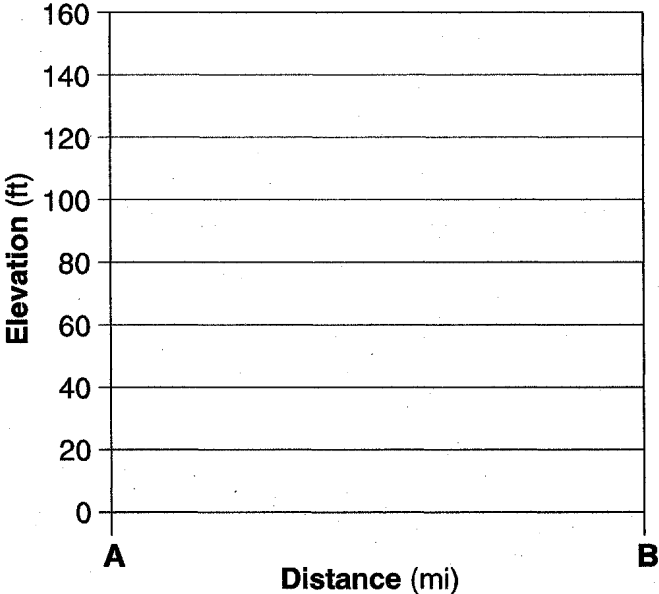

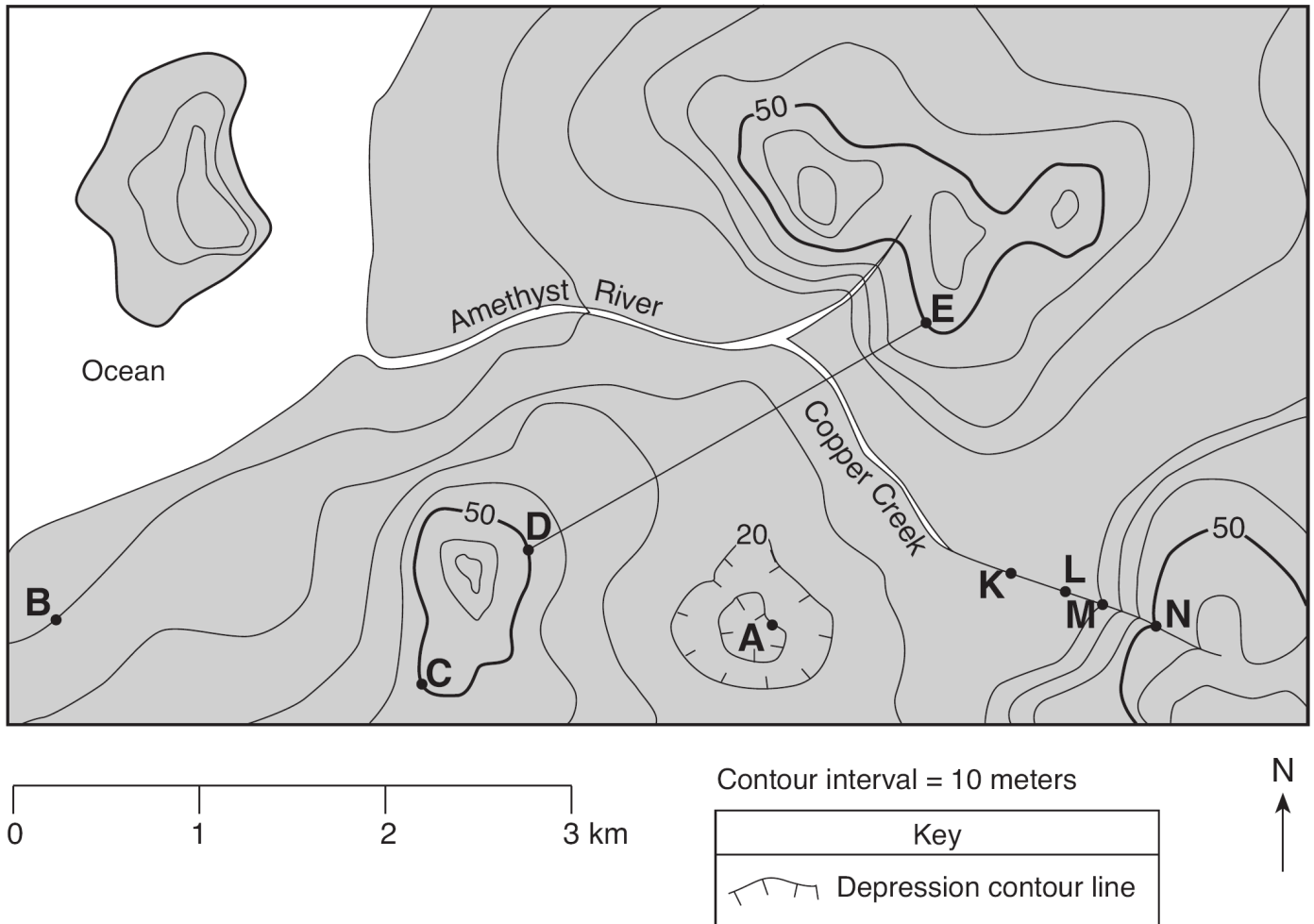

8. Base your answer to the following question on the topographic map shown below. Letters *A*, *B*, *C*, *D*, and *E* represent locations on Earth's surface. Letters *K*, *L*, *M*, and *N* are locations along Copper Creek. Elevations are measured in meters.

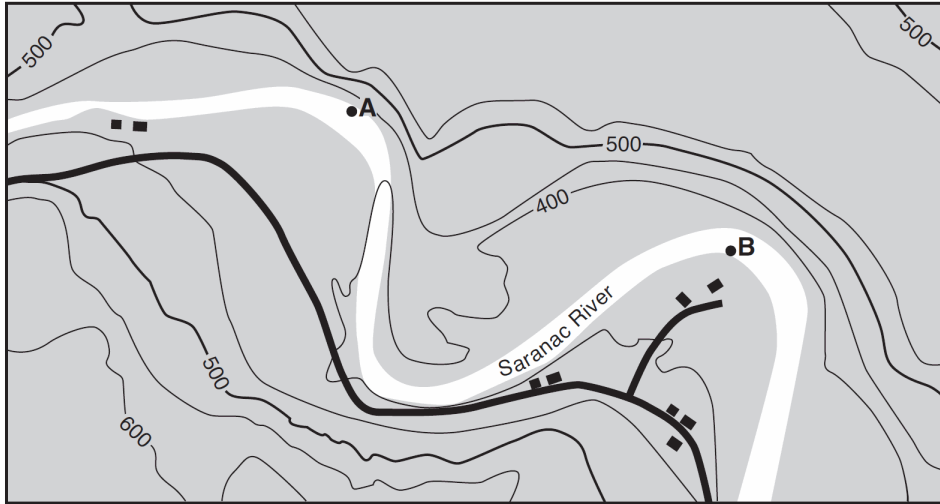

Explain how the map indicates that Copper Creek flows faster between points *N* and *M* than between points *L* and *K*.

Base your answers to questions 9 and 10 on the topographic map below, which shows an area of the Saranac River just west of Plattsburgh, New York. Points *A* and *B* are locations in the river.



Key	
	Road
	Building

Contour interval = 50 ft



9. Why is erosion of the stream bank more likely at point *A* than at point *B*?
10. Describe how the contour lines shown on the map indicate that the Saranac River flows from point *A* to point *B*.

11. Base your answer to the following question on the map below, which shows partially drawn contour lines. Xs indicate elevations in meters. Letters A, B, C, and D represent locations on the map.

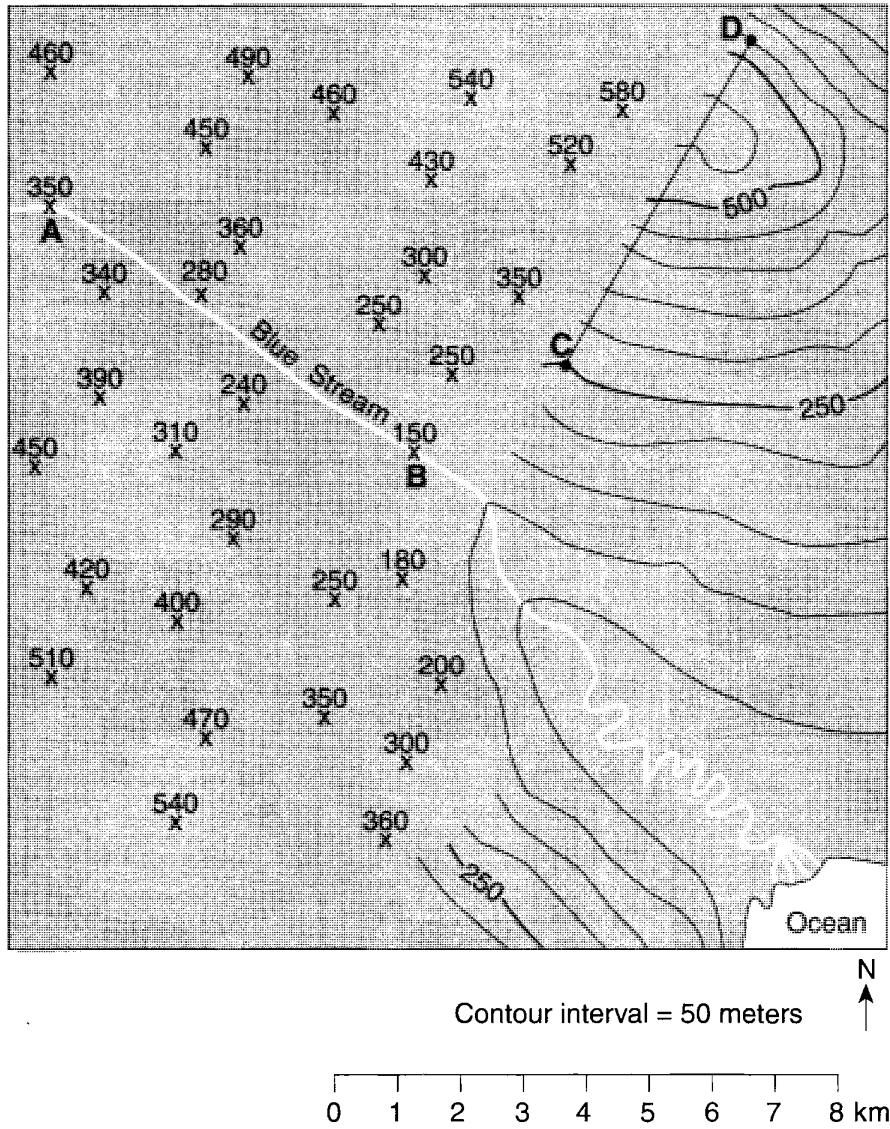

Calculate the stream gradient from elevation A to elevation B. Label your answer with the correct units.

12. Base your answer to the following question on the field map below. The map shows elevations, measured in feet, of a number of points in a certain geographic region. Contour lines have been drawn for the 100-foot and 120-foot elevations. Points *A* and *B* represent two spot elevations on the map.

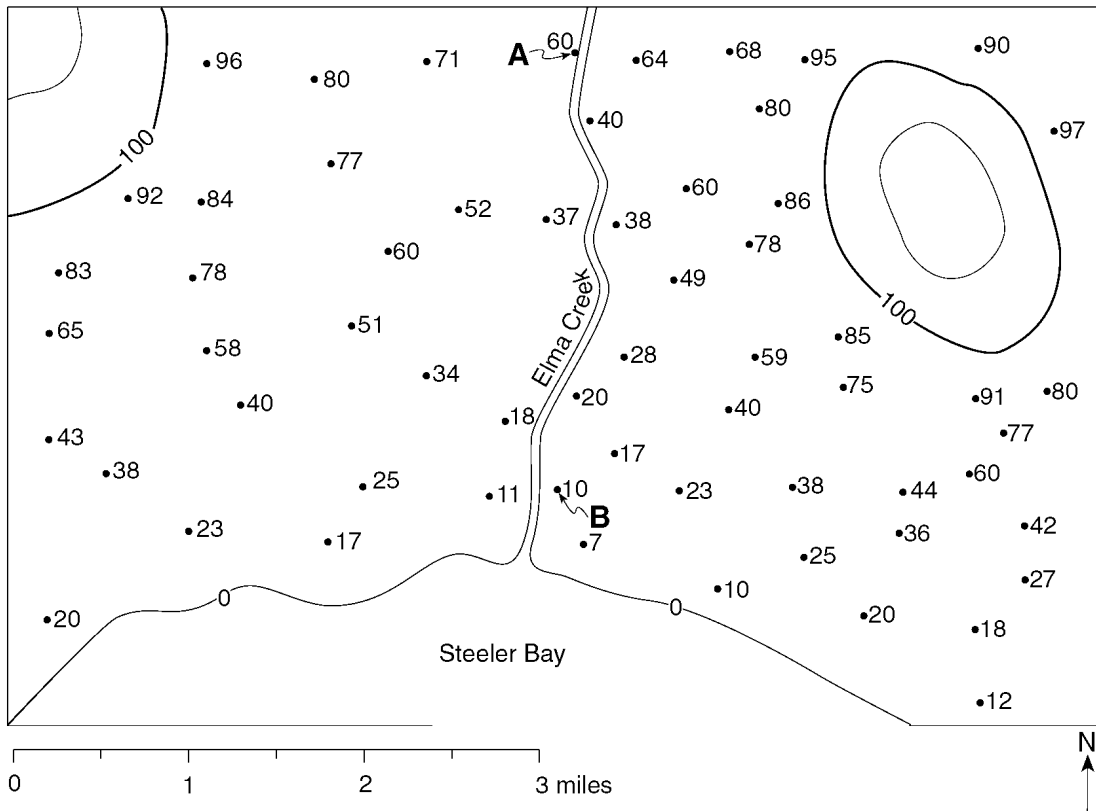

On the diagram above, draw the 60-foot contour line. Make sure that the contour line extends to the edges of the map.

Base your answers to questions 13 and 14 on the diagram below, which shows a clear plastic tube containing water and a beaker containing a mixture of rounded quartz grains of different sizes.

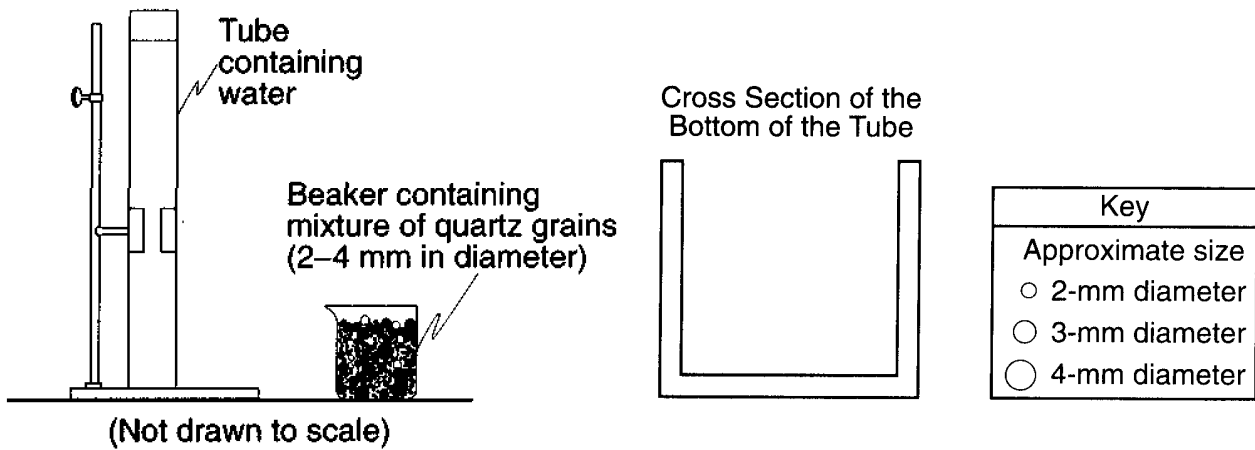

Side View of Stream

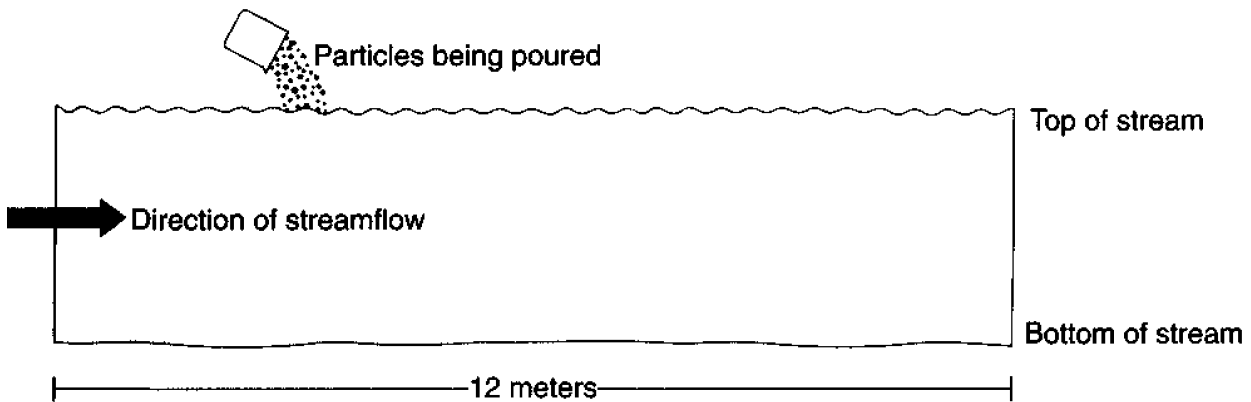

- When the rounded quartz grains are poured all at once into the tube, the grains will settle to the bottom of the tube. On the cross section provided above, draw the approximate grain sizes and pattern of arrangement of the rounded quartz grains at the bottom of the tube.
- The side-view diagram above shows the same mixture and amount of rounded quartz grains being poured all at once into a moving stream with a depth of 3 meters. Describe the general location of the 2-mm-diameter rounded quartz grains compared to the 4-mm-diameter rounded quartz grains as they are transported and deposited downstream.

15. Base your answer to the following question on the topographic map below, which shows three glaciers found in Alaska. Dashed lines show the inferred location of the front edge of each glacier in 1948, 1964, and 1980. Solid lines show the location of the front edge of each glacier in 1998. Points *A* and *B* show the location of the front edge of the Taku Glacier in 1948 and 1998. Elevations are in feet.

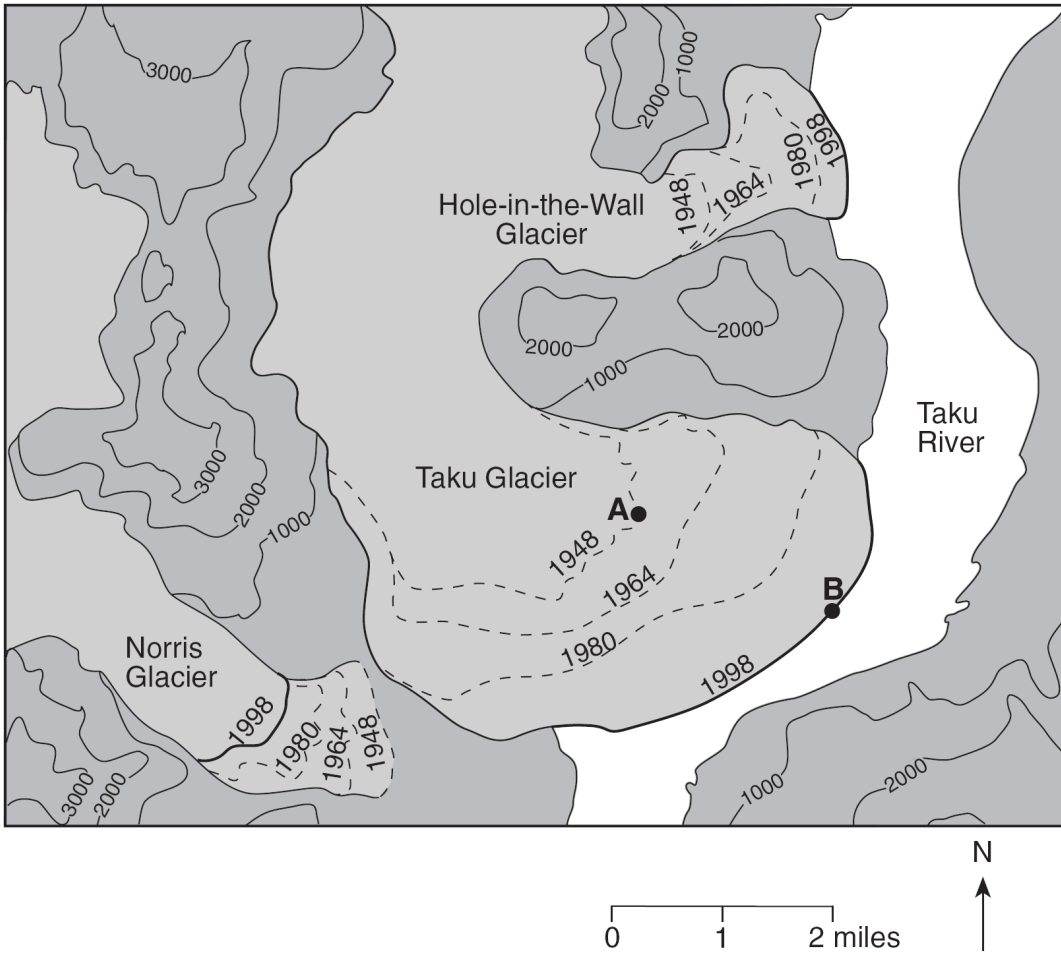

If these glaciers completely melted, what *two* pieces of evidence would a scientist most likely find to indicate that glaciers had existed in this area?

-
16. Base your answer to the following question on the photograph below, which shows a mountainous region cut by a large valley in its center.



What characteristic of this large valley supports the inference that glacial ice formed the valley?

Base your answers to questions **17** and **18** on the cross section and block diagram below. The cross section shows an enlarged view of the stream shown in the block diagram. The sediments in the cross section are drawn to actual size. Arrows show the movement of particles in the stream. The block diagram represents a region of Earth's surface and the bedrock beneath the region.

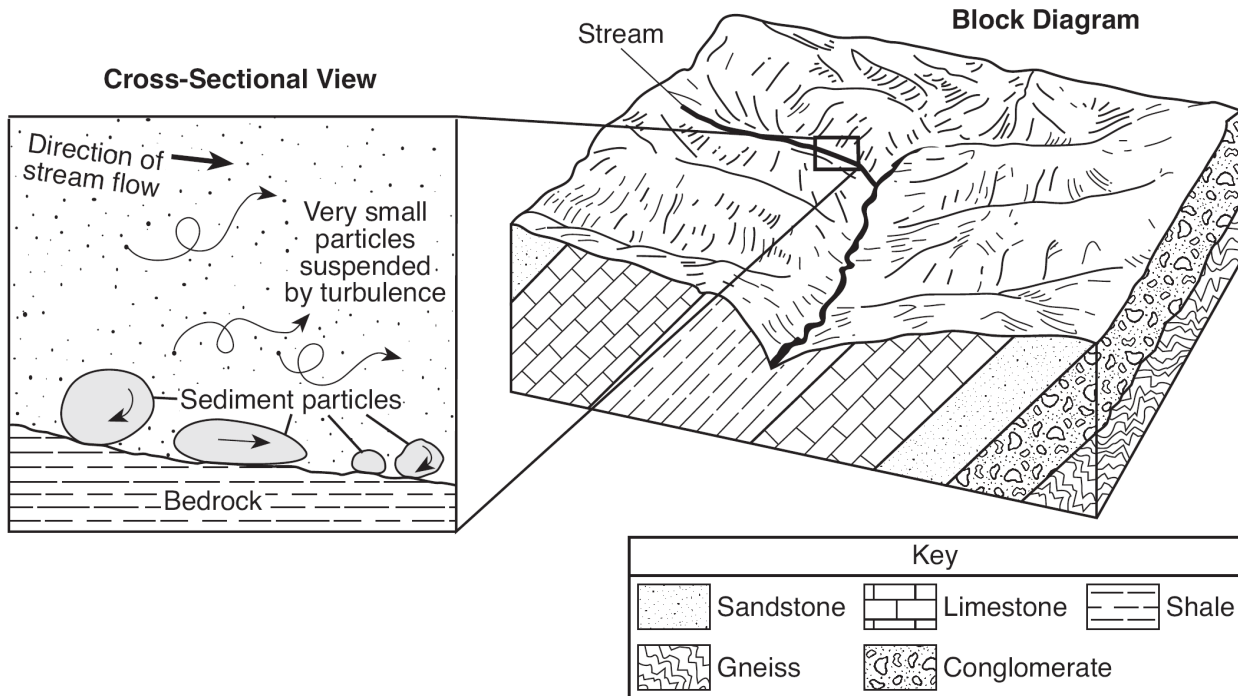

17. What process is responsible for producing the rounded shape of the particles shown on the stream bottom in the cross section?
18. How does the shape of a valley eroded by a glacier differ from the shape of the valley shown in the block diagram?

19. Base your answer to the following question on the map below, which shows the generalized surface bedrock for a portion of New York State that appears in the Earth Science Reference Tables.

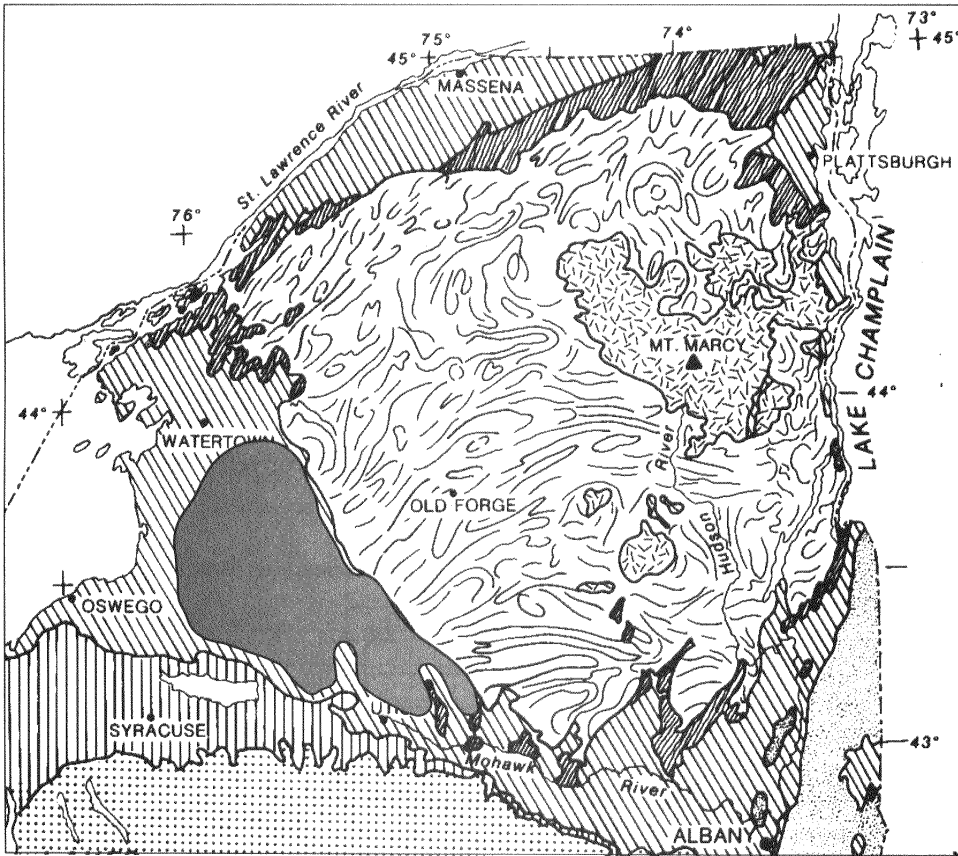

Place an X on the map to represent a location in the Tug Hill Plateau landscape region.

20. Part of which generalized New York State landscape region is drained by the Susquehanna River and its tributaries?
21. New York States Adirondacks are classified as a mountain landscape region. Describe one bedrock characteristic and one land surface characteristic that were used to classify the Adirondacks as a mountain landscape region.

Base your answers to questions 22 and 23 on map A and map B, and map C below, which show evidence that much of New York State was once covered by a glacial ice sheet. Map A shows the location of the Finger Lakes Region in New York State. The boxed areas on map A were enlarged to create maps B and C. Map B shows a portion of a drumlin field near Oswego, New York. Map C shows the locations of glacial moraines and outwash plains on Long Island, New York.

Map A

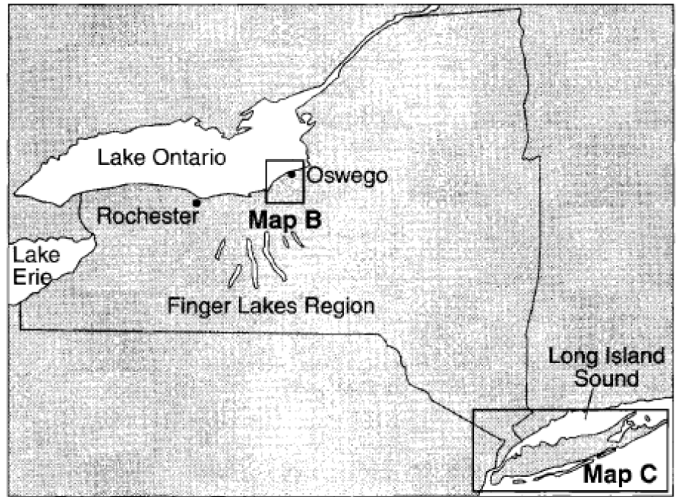

Map B

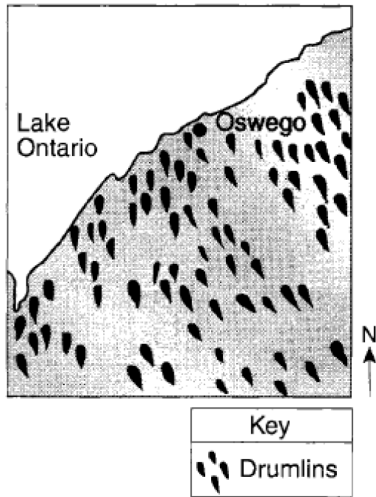

Map C

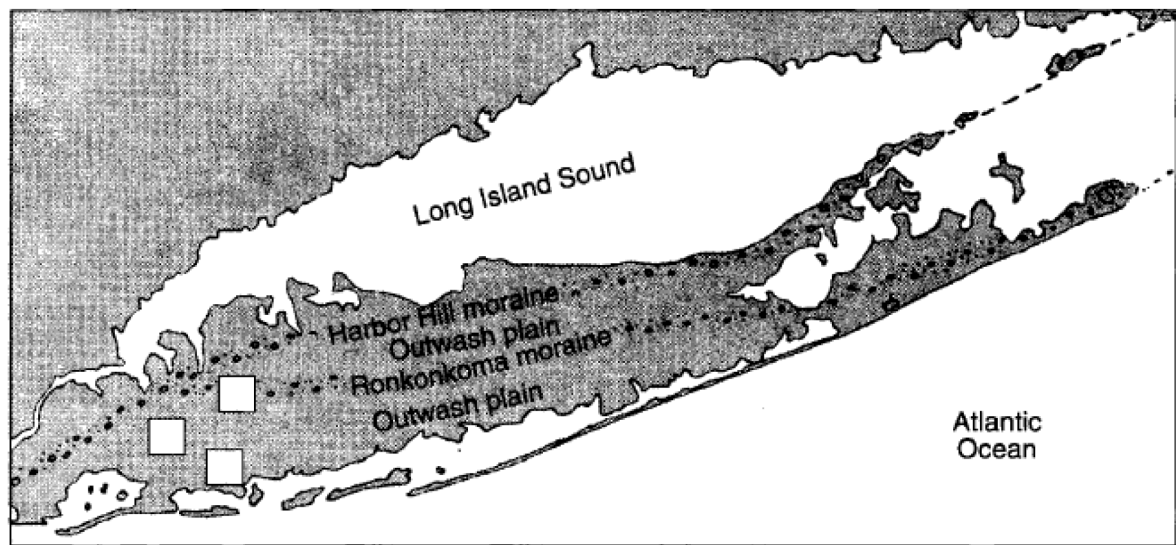

22. The diagrams below represent three sediment samples labeled X, Y, and Z. These samples were collected from three locations marked with empty boxes on map C in your answer booklet.

Sample X

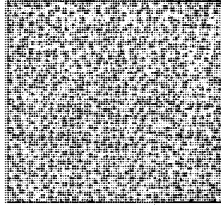

Sorted particle-size range:
0.005–0.09 cm

Sample Y

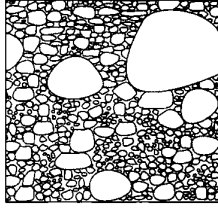

Unsorted particle-size range:
0.01–62 cm

Sample Z

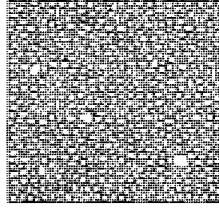

Sorted particle-size range:
0.1–0.3 cm

(Not drawn to scale)

Write the letter of each sample in the correct box on map C to indicate the location from which each sample was most likely collected.

23. The drawing below shows a glacial erratic found on the beach of the north shore of Long Island near the Harbor Hill moraine. This boulder is composed of one-billion-year-old gneiss.

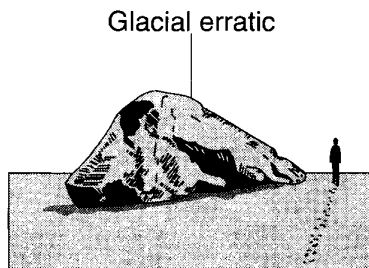

Which New York State landscape region has surface bedrock similar in age to this erratic?

Base your answers to questions 24 and 25 on the geologic cross section shown below, which shows the surface of a landscape region in the southwestern United States and indicates the age, type, and thickness of the bedrock.

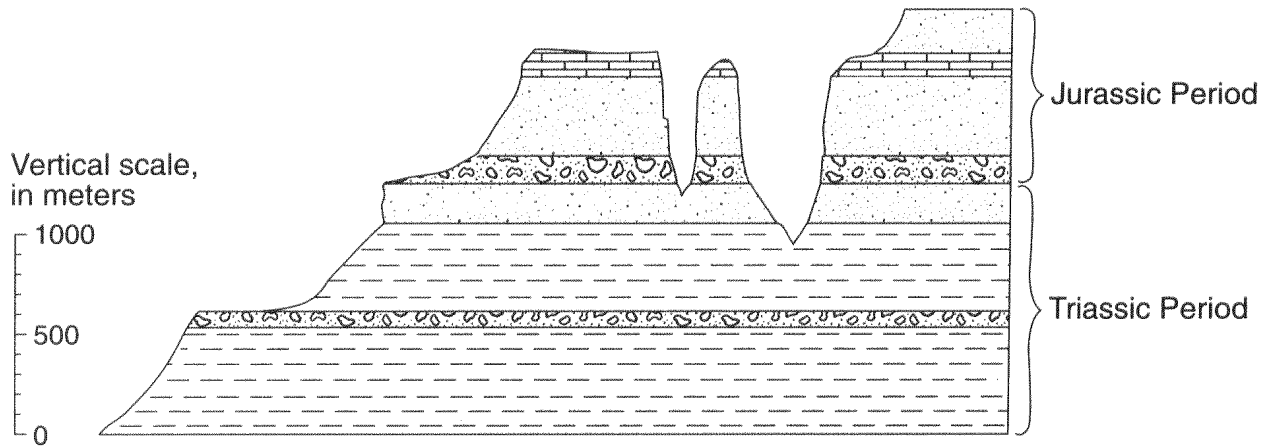

24. Which New York State landscape region has surface bedrock of the same geologic age as the surface bedrock shown in this cross section?
25. State *one* characteristic, other than the horizontal bedrock structure, shown in the cross section that supports the idea that this region is correctly classified as a plateau landscape.

Base your answers to questions 26 and 27 on the block diagram below, which shows the landscape features of an area of Earth's crust. Two sedimentary rock layers, *A* and *B*, are labeled in the diagram. The rock symbol for layer *B* has been omitted.

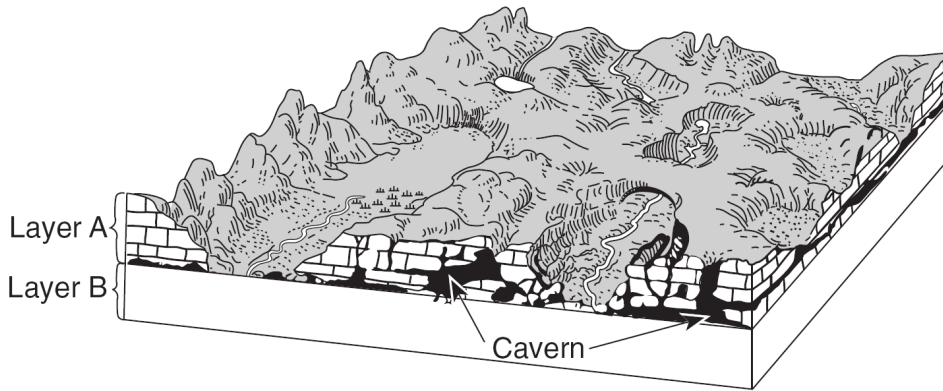

26. The graph below shows the particle sizes that compose the clastic sedimentary rock in layer *B*.

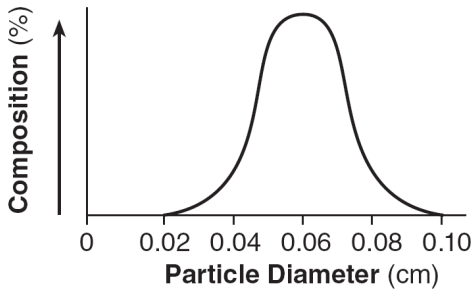

In the area below, draw the map symbol that represents rock layer *B*.

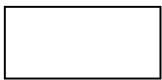

27. Describe how the caverns formed in rock layer *A*.

28. Base your answer to the following question on the diagram below, which shows igneous rock that has undergone mainly physical weathering into sand and mainly chemical weathering into clay.

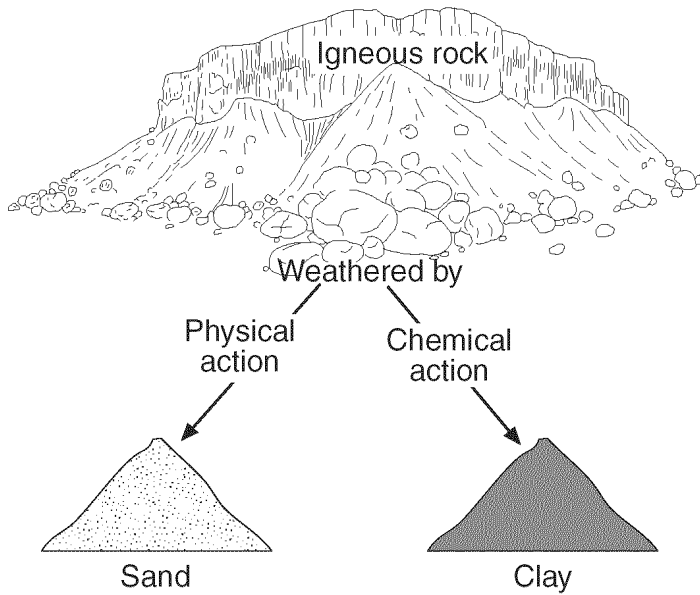

Compare the particle size of the physically weathered fragments to the particle size of the chemically weathered fragments.

- Base your answers to questions 29 and 30 on cross section below, which shows the general pattern of water movement in the water cycle. Letter X represents a water-cycle process.

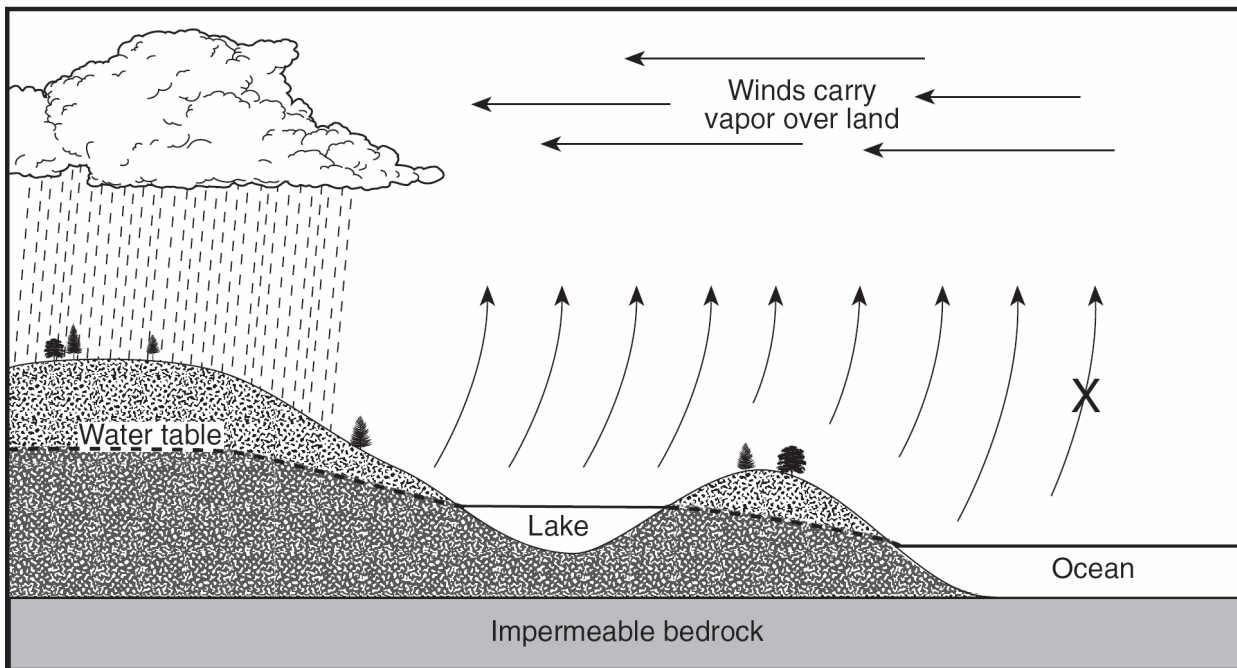

29. What process of the water cycle is represented by X?

30. Explain *one* role of plants in the water cycle.

6.GROUND WATER (5)

6.C.Constructed Response VI (5)

8.THE DEPOSITIONAL PROCESS (15)

8.E.Constructed Response VIII (14)

8.C.Landscape Characteristics (1)

8.C.iii.Landscape Regions of New York State (1)

2.DESCRIBING THE EARTH (6)

2.C.Constructed Response II (6)

7.THE EROSIONAL PROCESS (4)

7.C.Constructed Response VII (4)

Mid Year Review SAR

1. *Examples:* –The larger the sediment size, the greater the permeability. –The smaller the particles, the slower the water flows through.
–There is a direct relationship.

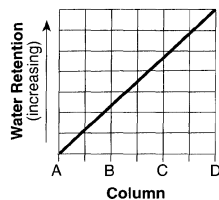

2. Column A
3. — More deposition has occurred on the inside of the meander.
— Stream water moves slower on the inside curve.
— More erosion occurs on the outside of a bend.
— B is located on the outside of a meander.
4. Responses include, but are not limited to: Stream velocity is greater on the outside of the meandering channel; Stream flow is slower on the inside of the meandering channel; Water is moving faster on the outside of a meander curve

5. Responses include, but are not limited to: Glacial sediment is unsorted; piles of mixed sediment sizes.

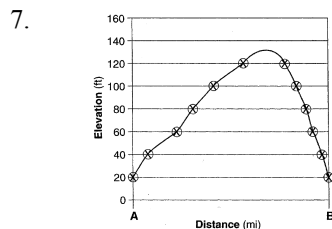

6. *Examples:* — Contour lines between N and M are closer together.
— There is a steeper slope between N and M. — Where contour lines are far apart, there is a gentle slope and the stream velocity is less.
7. — Erosion is greater on the outside of the meander curve. — The velocity of the stream is greater at point A.

8. — The contour line bends upstream when crossing the river. — The elevation of the river near the western edge of the map is 450 ft, but is only 400 ft farther east.
9. any value from 28.0 to 29.0 the correct units.

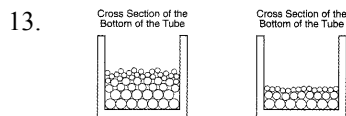
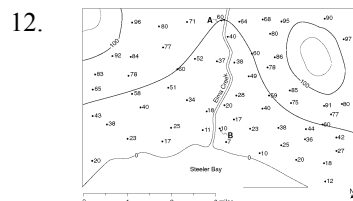

10. *Examples:* — The 2-millimeter grains settle farther downstream than the 4-millimeter grains. — The 2-millimeter grains settle farther to the right. — The larger grains are not carried as far.

11. *Examples:* — U-shaped valleys in the area — parallel scratches in the bedrock — unsorted sediment deposits — moraines — drumlins

12. • The valley has a U-shaped cross section. • The bottom of the valley is round. • Nonglaciaded mountain valleys are V-shaped; this one is U-shaped.

13. *Examples:* — abrasion — weathering — erosion — Particles were worn down as they were scraped along the bedrock.

14. *Examples:* — A glacier forms a U-shaped valley. — Glaciers form U-shaped valleys and streams form V-shaped valleys.

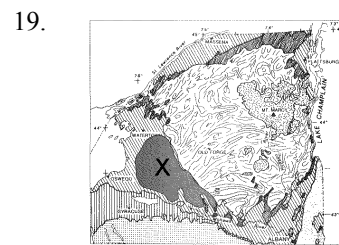

15. *Examples:* – Allegheny Plateau – Appalachian Plateau (uplands) – Catskills

16. Bedrock characteristics: – The Adirondacks have faulted, folded, and deformed bedrock. – The Adirondacks have intensely metamorphosed bedrock. – The oldest bedrock is near the center of the Adirondacks. Land surface characteristics: – The Adirondacks have high elevations. – The Adirondacks have steep slopes. – The Adirondacks are a partially eroded dome.

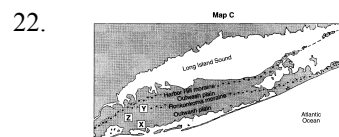

17. Hudson Highlands or Adirondack Mountains.
18. Newark Lowlands

Answer Key
Mid Year Review SAR

25. Examples: – The landscape has a high relief. – There is a large difference in elevation between the top and bottom rocks in the cross section.

30. *Examples:* — Plants release water into the air by transpiration. — Runoff is slowed by plants, so more infiltration can occur.

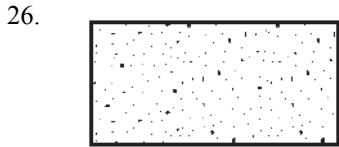

27. *Examples:* — Limestone reacts with acids in groundwater. — Acids in water cause limestone to dissolve. — Chemical weathering of limestone — Water flowing through cracks removes limestone.

28. – The physically weathered sediments are larger in particle size than the chemically weathered particles.
– The sand fragments are larger than clay fragments.
– The sand fragments range from 0.006 cm to 0.2 cm in diameter and the clay fragments are less than 0.0004 cm in diameter.

29. evaporation.